

Monitor for continuous measurement of dissolved hydrogen in water steam cycles.

Monitor AMI Hydrogen QED

Complete system mounted on stainless steel panel:

- **Transmitter AMI Hydrogen** in a rugged aluminum enclosure (IP 66).
- **Flow cell QV-Flow PMMA OTG** made of acrylic glass with needle valve and digital sample flow meter on mounting angle made of stainless steel.
- **Swansensor Hydrogen** with platinum anode and silver cathode and integrated NT5k temperature sensor.
- **Faraday electrode** for the automatic or manual verification by electrochemically generated hydrogen concentration in the ppb range.
- Factory tested, ready for installation and operation.

Specifications:

- Measuring range:
0.01 ppb to 800 ppb H₂ (at 25°C, 1013hPa) or
0 – 50% saturation
- Automatic air pressure compensation
- Automatic temperature compensation
- Simultaneous measurement of dissolved hydrogen, sample temperature and sample flow.
- Big backlit LC display for the reading of measuring value, sample temperature, sample flow and operating status.
- Easy user menus in English, German, French and Spanish. Simple programming of all parameters by keypad.
- Two current outputs (0/4 - 20 mA) for measured signals (3rd output optional).
- Electronic record of major process events and calibration data

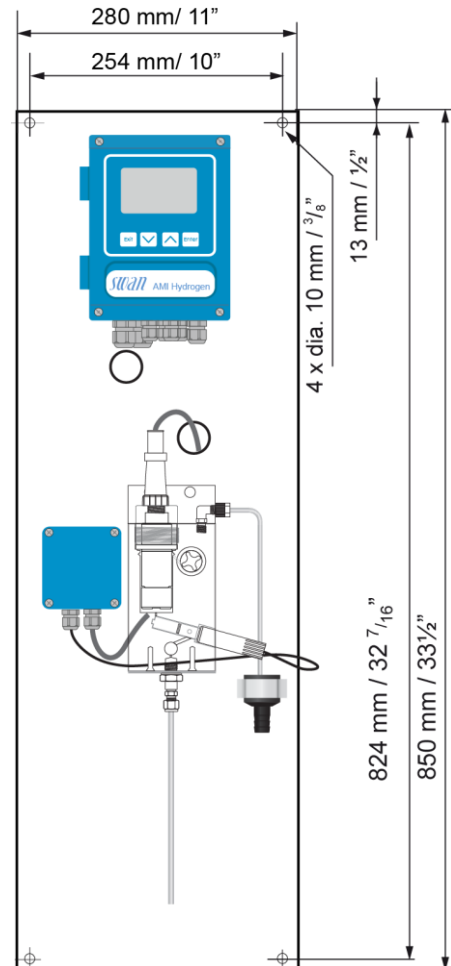

Order Nr.	Monitor AMI Hydrogen QED	A-22.851.000
Option:	<input type="checkbox"/> 3 rd current signal output (0/4 – 20mA)	A-81.410.020
	<input type="checkbox"/> Profibus DP interface	A-81.420.020
	<input type="checkbox"/> HyperTerminal interface (RS-232)	A-81.420.010
	<input type="checkbox"/> Modbus interface	A-81.420.022
	<input type="checkbox"/> USB interface	A-81.420.040

Dissolved Hydrogen Measurement

Swansensor-Hydrogen with platinum anode and silver cathode and with integrated NT5k temperature sensor.

Measuring range	Resolution
0.01 to 9.99 ppb	0.01 ppb
10.0 to 99.9 ppb	0.1 ppb
100 to 800 ppb	1 ppb
0-50% saturation	0.1% saturation
Automatic range switching	

Automatic temperature and air pressure compensation.

Accuracy / Repeatability

Accuracy: ± 5% of reading or ± 0.5 ppb
Repeatability: ± 1% of read. or ± 0.5 ppb (whichever is greater)

Response time

$t_{90} < 40$ sec. or ± 1 ppb
(rising concentration, whichever is greater)

Faraday verification

In-line, electrochemical generation of hydrogen in ppb range (value dep. on flow rate, recommended up to max. 50ppb) by faraday electrode made of platinum.

Temperature measurement NT5k

Measuring range: -30 to +130 °C
Resolution: 0.1 °C

Sample flow measurement

With digital SWAN sample flow sensor

Transmitter Specifications and Functionality

Electronics case: Cast aluminum
Protection degree: IP 66 / NEMA 4X
Display: backlit LCD, 75 x 45 mm
Electrical connectors: screw clamps
Dimensions: 180 x 140 x 70 mm
Weight: 1.5 kg
Ambient temperature: -10 to +50 °C
Humidity: 10 - 90% rel., non condensing

Power supply

Voltage: 100 - 240 VAC (± 10 %)
50/60 Hz (± 5 %)
or 24 VDC (± 10 %)
Power consumption: max. 30 VA

Operation

Easy operation based on separate menus for "Messages", "Diagnostics", "Maintenance", "Operation" and "Installation".

User menus in English, German, French and Spanish.

Separate menu specific password protection.

Display of process value, sample flow, alarm status and time during operation.

Storage of event log, alarm log and calibration history.

Storage of the last 1'500 data records in log with selectable time interval.

Electrical Connection Scheme

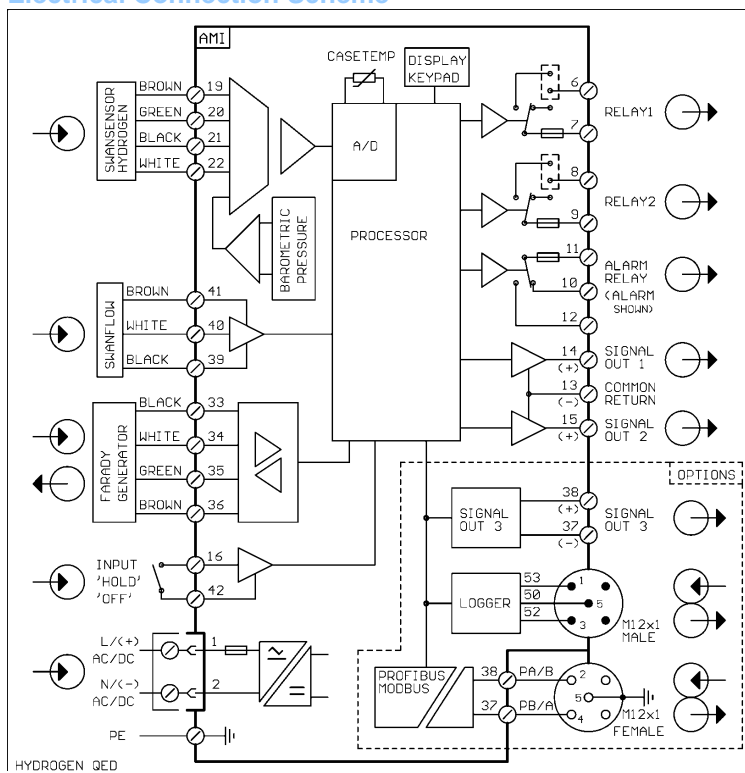

Safety features

No data loss after power failure, all data is saved in non-volatile memory.
Over-voltage protection of in- and out-puts.
Galvanic separation of measuring inputs and signal outputs.

Transmitter temperature monitoring with programmable high/low alarm limits.

1 Alarm relay

One potential free contact for summary alarm indication for programmable alarm values and instrument errors.
Maximum load: 1A / 250 VAC

1 Input

One input for potential-free contact. Programmable hold or remote off function.

2 Relay outputs

Two potential-free contacts programmable as limit switches for measuring values, controllers or timer for system cleaning with automatic hold function.
Rated load: 1A / 250 VAC

2 Signal outputs (3rd as option)

Two programmable signal outputs for measured values (freely scalable, linear or bilinear) or as continuous control output (control parameters programmable).
Current loop: 0/4 - 20 mA
Maximum burden: 510 Ω

Control functions

Relays or current outputs programmable for 1 or 2 pulse dosing pumps, solenoid valves or for one motor valve. Programmable P, PI, PID or PD control parameters.

1 Communication interface (option)

- RS232 interface for logger download to PC with SWANterminal
- RS485 interface (galvanically separated) with Fieldbus protocol Modbus or Profibus DP
- 3rd Signal output
- USB interface

Monitor Data

Sample conditions

Flow rate: 6 to 20 l/h
Temperature: up to 45 °C
Inlet pressure: 0.2 to 1 bar
Outlet pressure: pressure free
Suspended solids: less than 10 ppm

Flow cell and connections

Flow cell made of acrylic glass with built-in flow adjustment valve and digital sample flow meter

Sample inlet:

Swagelok 1/4" tube adapter

Sample outlet:
for flexible tube Ø 20 x 15 mm

Panel

Dimensions: 280 x 850 x 150 mm
Material: stainless steel
Total weight: 12.0 kg