

Monitor for continuous measurement of Ammonium, Nitrate or Fluoride in potable water.

Monitor AMI ISE Universal

Complete system mounted on PVC panel:

- **Transmitter AMI ISE Universal** in a rugged aluminum enclosure (IP 66).
- **Flow cell M-Flow 10-3PG** including temperature sensor (NT5K).
- Factory tested, ready for installation and operation.

For use with:

- **Swansensor Ammonium, – Nitrate or - Fluoride**
- **Swansensor Reference FL**

Optional:

- Swansensor deltaT for flow detection

Specifications:

- Measuring ranges: 0.1 to 1'000 ppm (= mg/l).
- Simultaneous measurement of process value, sample temperature and sample flow (optional).
- Automatic temperature compensation according to Nernst.
- Big backlit LC display for the reading of measuring value, sample temperature, sample flow and operating status.
- Easy user menus with simple programming of all parameters by keypad.
- Electronic record of major process events and calibration data.
- Real-time clock for time stamp in data logs and for automated functions.
- Data logger for 1'500 data records stored at a selectable interval. (Data download to PC requires optional HyperTerminal interface).
- Overvoltage protection for in- and outputs.
- Two current outputs (0/4 - 20 mA) for measured signals.
- Potential-free alarm contact as summary alarm indication for programmable alarm values and for instrument faults.
- Two potential-free contacts programmable as limit switch or PID-control.
- Input for potential-free contact to freeze the measuring value or to interrupt control in automated installations (hold function or remote-off).

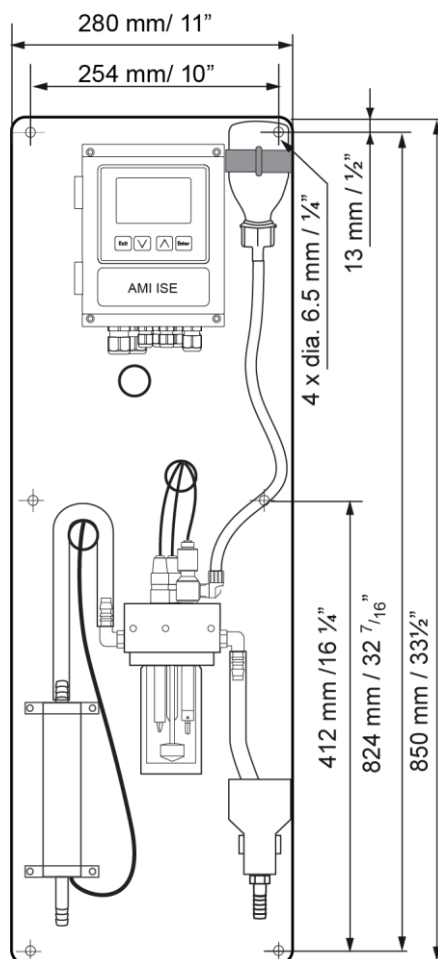

Picture: Monitor AMI ISE Universal with deltaT-Flow detection, SS Ammonium, SS Temp NT5K and SS Reference FL.

Order Nr.	Monitor AMI ISE Universal	A-27.201.010
Option:	<input type="checkbox"/> Swansensor Ammonium	A-87.710.010
	<input type="checkbox"/> Swansensor Nitrate	A-87.730.010
	<input type="checkbox"/> Swansensor Fluoride	A-87.760.010
Option:	<input type="checkbox"/> Swansensor Reference FL	A-87.860.100
Option:	<input type="checkbox"/> 3 rd current signal output (0/4 – 20mA)	A-81.420.050
	<input type="checkbox"/> Profibus DP & Modbus RTU interface (RS-485)	A-81.420.020
	<input type="checkbox"/> USB interface	A-81.420.042
Option:	<input type="checkbox"/> Swansensor deltaT Flow	A-87.933.010

**NH4-N / NO3-N / F
Measurement**

Signal input galvanically separated
Input resistance: > 10¹³ Ω

Ammonium, Nitrate or Fluoride measurement with appropriate Sensor.
Measuring range: 0.1 to 1'000 ppm
Display: Resolution
0.00 to 9.99 0.01 ppm
10.0 to 99.9 0.1 ppm
100 to 1'000 1 ppm
Reference temperature: 25 °C
Automatic temperature compensation according to Nernst.

Restriction of use: direct control of fluoride dosing is not permitted.

Temperature measurement with Swansensor Temperature (NT5K).
Measuring range: -10 to + 50 °C
Resolution: 0.1 °C

Transmitter Specifications and Functionality

Electronics case: Cast aluminum
Protection degree: IP 66 / NEMA 4X
Display: backlit LCD, 75 x 45 mm
Electrical connectors: screw clamps
Dimensions: 180 x 140 x 70 mm
Weight: 1.5 kg
Ambient temperature: -10 to +50 °C
Humidity: 10 - 90% rel., non condensing

Power supply
Voltage: 100 - 240 VAC (± 10 %),
50/60 Hz (± 5 %)
or 24 VDC (± 10 %)
Power consumption: max. 30 VA

Operation
Easy operation based on separate menus for "Messages", "Diagnostics", "Maintenance", "Operation" and "Installation".
User menus in English, German, French and Spanish.
Separate menu specific password protection.
Display of process value, sample flow, alarm status and time during operation.
Storage of event log, alarm log and calibration history.
Storage of the last 1'500 data records in logger with selectable time interval.

Safety features
No data loss after power failure, all data is saved in non-volatile memory.
Overvoltage protection of in- and outputs.
Galvanic separation of measuring inputs and signal outputs.

Electrical Connection Scheme

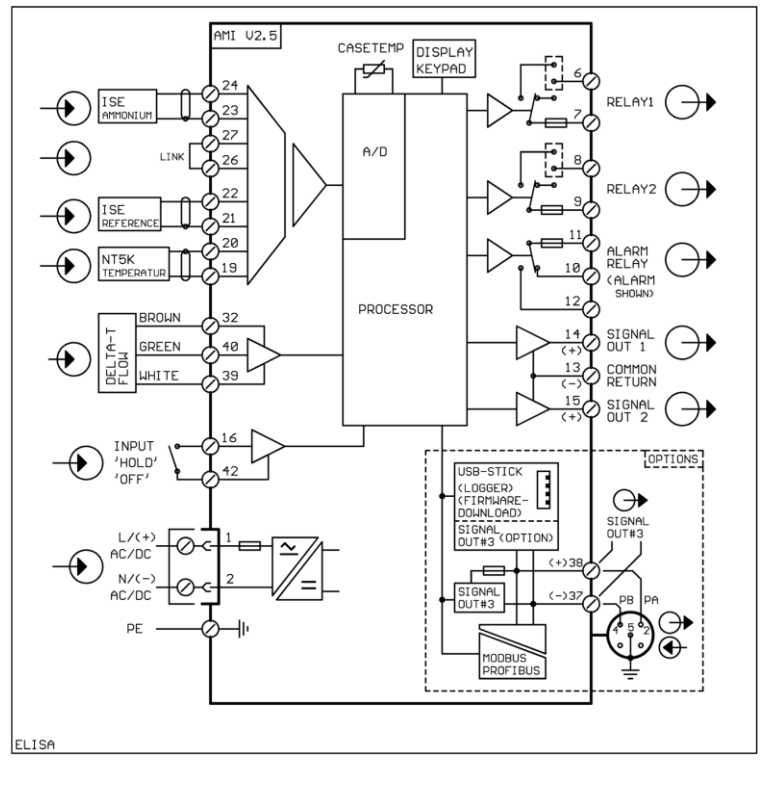

Transmitter temperature monitoring with programmable high/low alarm limits.

1 Alarm relay
One potential free contact for summary alarm indication for programmable alarm values and instrument faults.
Maximum load: 1 A / 250 VAC

1 Input
One input for potential-free contact. Programmable hold or remote off function.

2 Relay outputs
Two potential-free contacts programmable as limit switches for measuring values, controllers or timer for system cleaning with automatic hold function.
Rated load: 1 A / 250 VAC

2 Signal outputs (3rd as option)
Two programmable signal outputs for measured values (freely scaleable, linear or bilinear) or as continuous control output (control parameters programmable) as current source. 3rd signal output selectable as current source or current sink.
Current loop: 0/4 - 20 mA
Maximum burden: 510 Ω

Control functions
Relays or current outputs programmable for 1 or 2 pulse dosing pumps, solenoid valves or for one motor valve. Programmable P, PI, PID or PD control parameters.

1 Communication interface (option)
- RS485 interface (galvanically separated) with Fieldbus protocol Modbus RTU or Profibus DP
- 3rd Signal output
- USB interface

Monitor Data

Sample conditions
Flow rate: 4 to 15 L/h
Temperature: up to 35 °C
Inlet pressure: up to 1 bar
Outlet pressure: pressure free

Flow cell and connections
Flow cell made of PVC and acrylic glass.
Sample inlet: Hose nozzle ¼"-10 elbow for Ø 10 mm tube
Sample outlet: G ½" adapter for flexible tube Ø 20 x 15 mm

Panel
Dimensions: 280 x 850 x 150 mm
Material: white PVC
Total weight: 6.0 kg